

Model G7-93 Rotary Gear Pump

Surex rotary gear pumps designed for foam extinguishing system. They are Self-Priming and can pump Multiple Viscosities of Foam or Water. This versatile design is suitable for Electric, PTO, Diesel/Gasoline Engine, Water Driven or Hydraulic drive motors.

Design Features:

- Timing Gears Synchronize the Two Pumping Rotors.
- Timing Gears Allow for DRY Running Without Damage.
- No Rotor Contact Allows for Pumping Foam or Water.
- Water Can Be Used for: Calibration, Testing and Training.

Technical Data:

Max Pressure: 2.0MPa | 20bar
 Max Speed: 1800RPM
 Viscosity : 9500cp max.[1]
 Connection Diameter: DN50(60.3 O.D.)、2"
 Connection Type: Groove、Thread、Flange
 Approvals: FM
 [1]Brookfield viscometer, spindle #4, speed 30rpm.

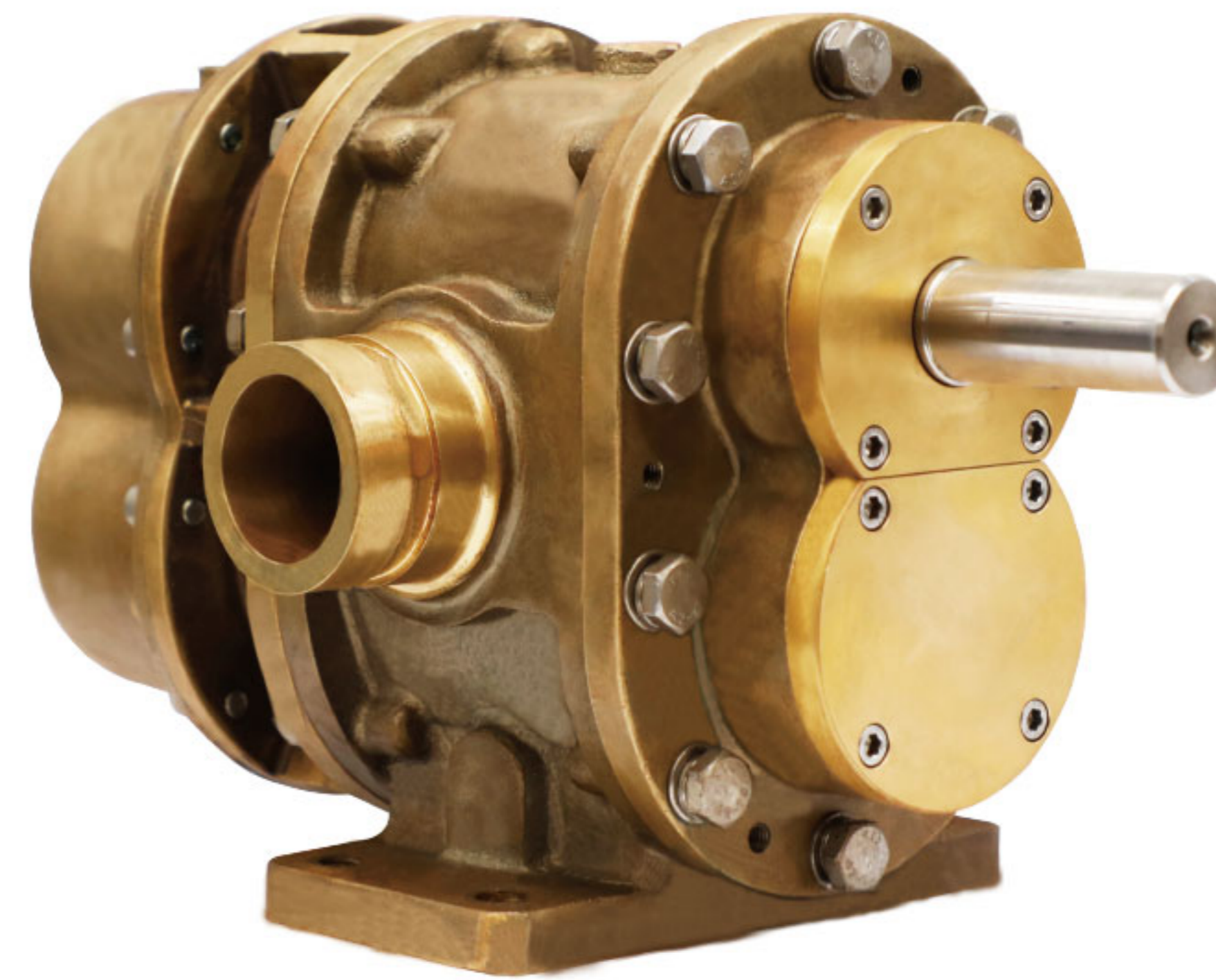

Materials :

Pump body: Red Brass, ASTM B584 C83600
 Rotor: Stainless Steel 17-4PH
 Red Brass, ASTM B584 C83600
 Liners: Red Brass, ASTM B584 C83600
 Front Cover: Red Brass, ASTM B584 C83600
 Back Cover: Red Brass ASTM B584 C83600
 Timing Gear: Alloy Steel 20CrMnTi (ASTM A29M)
 Lip Seal : FPM

Performance -Water

Foam Pump Pressure	1000rpm			1200rpm			1500rpm			1800rpm		
	Flow L/min	Power kw	Torque N.m	Flow L/min	Power kw	Torque N.m	Flow L/min	Power kw	Torque N.m	Flow L/min	Power kw	Torque N.m
5.0	193	4	34	254	4	34	347	6	39	436	8	41
6.9	178	5	44	239	5	44	331	7	48	421	9	50
10.3	155	6	61	217	8	61	308	10	64	398	13	66
13.8	138	8	77	201	10	78	291	13	80	381	16	83
17.2	127	10	93	191	12	95	280	15	96	370	19	99
20.0	122	11	105	186	14	108	275	17	110	365	21	111

Dimensions

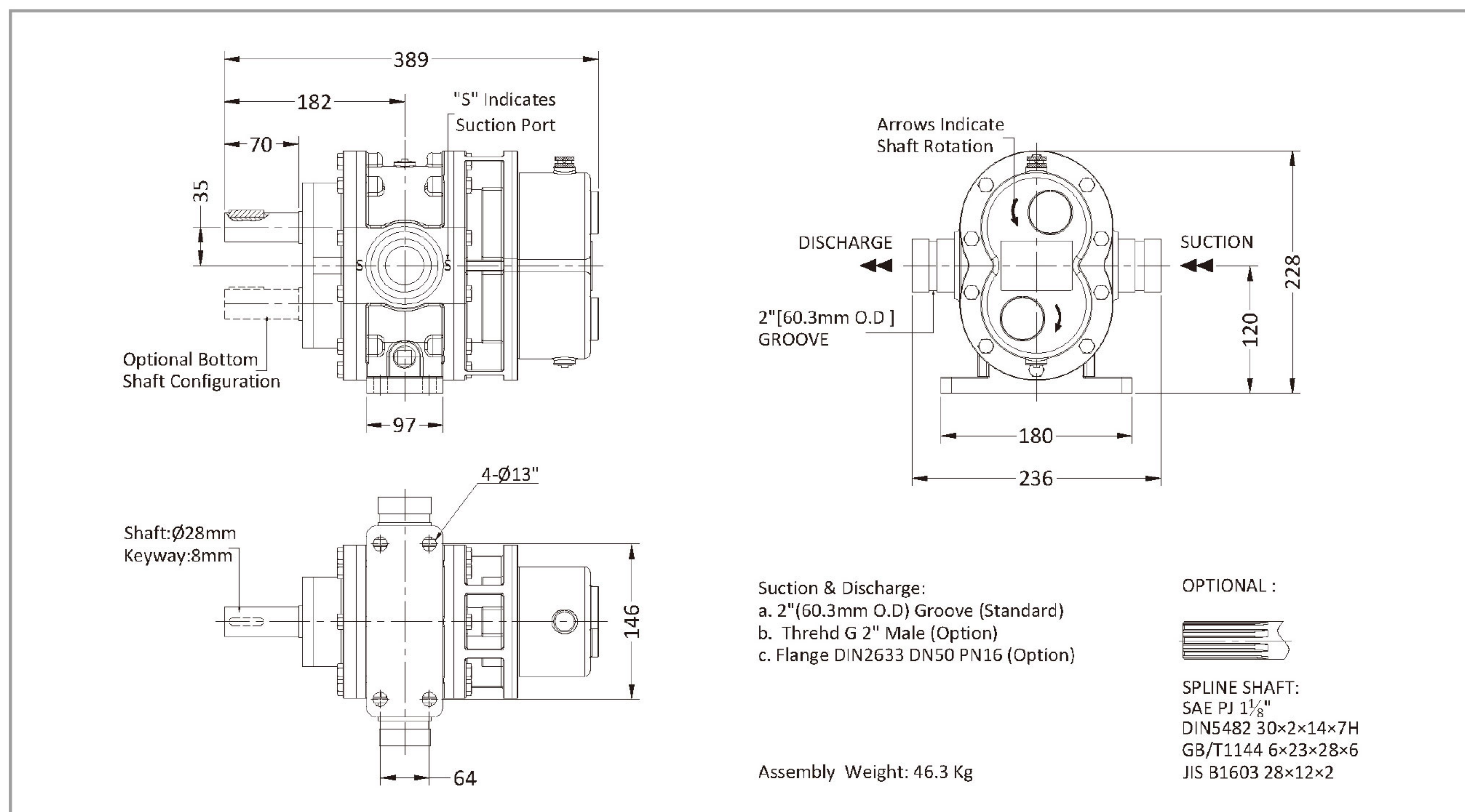

Model G7-93 Rotary Gear Pump

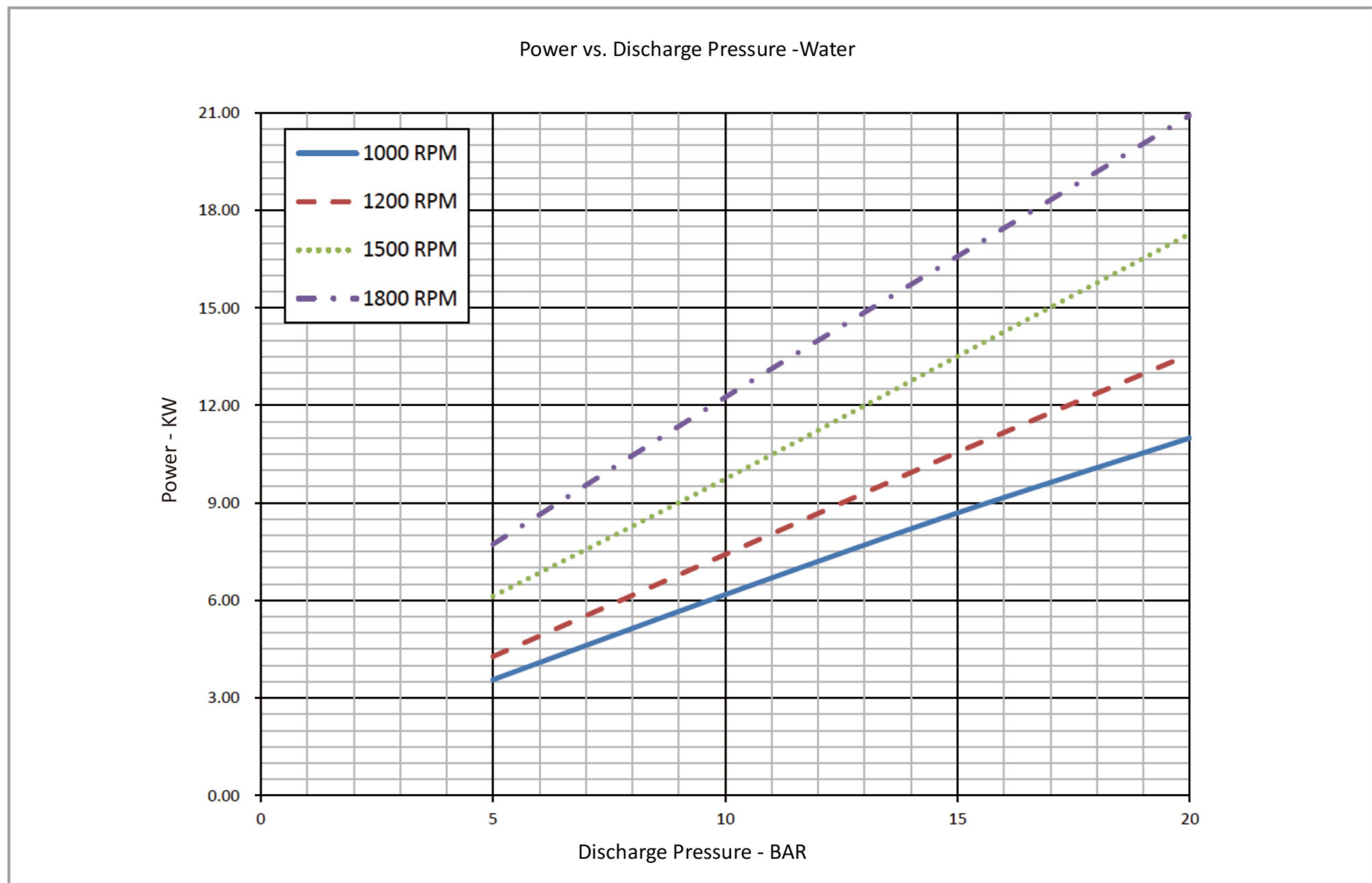
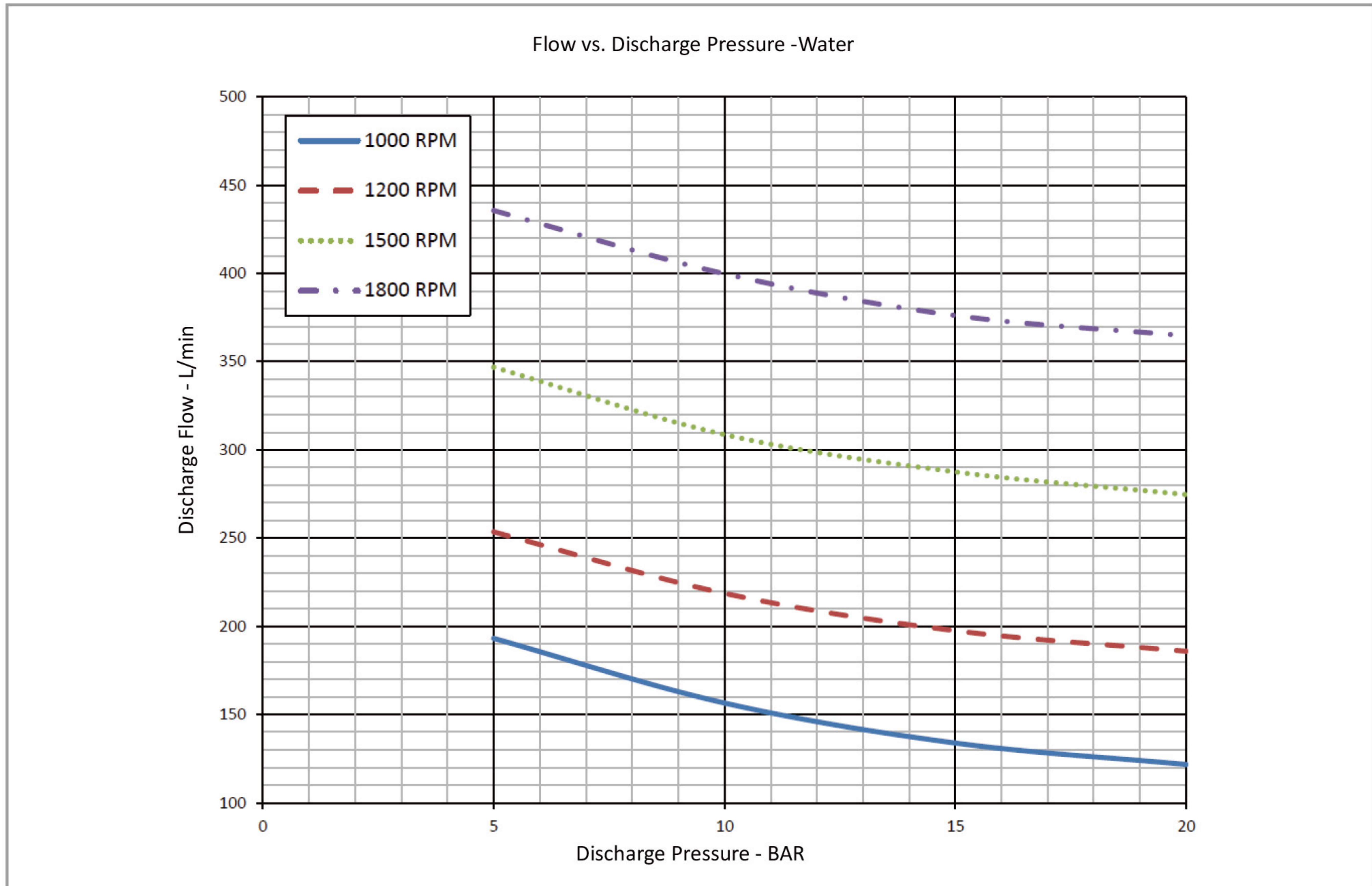

• The pump performance for foam concentrate, please contact Surex, or down load from www.surexfoam.com.